



MAXXIMUM

blenders

COMMERCIAL HI-PERFORMANCE BLENDERS

Project Name: _____
 Location: _____
 Item #: _____ Qty: _____
 Model #: _____

2 HP BLENDERS

SPECIFICATIONS

MODELS MMV, MMH, MMP, MMT SERIES 500

These models feature a powerful 2 horsepower motor with a capacity of 64 oz/2.0 liters. The compact design measures 17-1/2" x 7-3/4" x 9". Consumption is 110/60, 220/50, 220/60 volts and 1300 in watts. Shipping weight: Box of (1) 15 lbs./Case of (4) 59 lbs.

MODELS MMV, MMH, MMP, MMT SERIES 600

These models feature a powerful 2 horsepower motor with a capacity of 82 oz/2.5 liters. The compact design measures 20-1/2" x 7-3/4" x 9". Consumption is 110/60, 220/50, 220/60 volts and 1300 in watts. Shipping weight: Box of (1) 15 lbs./Case of (4) 59 lbs.

STANDARD FEATURES

MAXX MIX offers your choice of 2 container sizes to fit your exact needs.

64 oz/2.0 Liters (500 series)
 82 oz/2.5 Liters (600 series)

Powerful - The unique and powerful 2 horsepower motor provides exceptional performance and reduces down time. MAXX MIX is truly the best choice in commercial blenders.

Versatile- The powerful 2 hp motor lets you blend virtually anything that you may need. From salsas, fruits, soups and even ice for great frozen drinks, you can do it all in a MAXX MIX. It will be the only blender you will ever need.

Durable - Every MAXX MIX is over-built. It is made of polycarbonate to withstand the type of punishment that is required in a fast-paced environment. The stainless steel blade assembly is rust resistant and stays sharp longer than conventional blades.

Safe - Every MAXX MIX features an automatic shut off feature in the event of an overload.

Efficient - The unique design of the stainless steel blade is designed with precise angles to ensure consistent mixing every time.

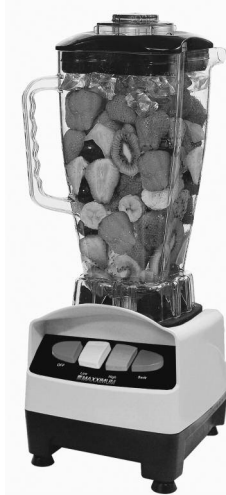

MMV Series
 Value Blender
 On/Off & High/Low & Pulse
 Push Button Controls



MMH Series
 Two Speed Blender
 On/Off & High/Low
 Toggle Control



MMP Series
 Variable Speed Blender
 On/Off & Variable Speed
 Toggle Control



MMT Series
 Variable Speed Blender
 On/Off & Variable Speed & Timer
 Toggle Control



Specifications subject to change without notice.
 Approvals:

MAXXIMUM

blenders

COMMERCIAL HI-PERFORMANCE BLENDERS

SPECIFICATIONS



MMV Series
Value Blender
On/Off & High/Low & Pulse
Push Button Controls



MMH Series
Two Speed Blender
On/Off & High/Low
Speed Toggle Control



MMP Series
Variable Speed Blender
On/Off & Variable speed
Toggle Control



MMT Series
Variable Speed Blender
On/Off & Variable Speed & Timer
Toggle Control

STANDARD FEATURES

MAXX MIX offers your choice of 2 container sizes to fit your exact needs.

64 oz/2.0 Liters (500 series)
82 oz/2.5 Liters (600 series)

Powerful - The unique and powerful 2 horsepower motor provides exceptional performance and reduces down time. MAXX MIX is truly the best choice in commercial blenders.

Versatile- The powerful 2 hp motor lets you blend virtually anything that you may need. From salsas, fruits, soups and even ice for great frozen drinks, you can do it all in a MAXX MIX. It will be the only blender you will ever need.

Durable - Every MAXX MIX is over-built. It is made of polycarbonate to withstand the type of punishment that is required in a fast-paced environment. The stainless steel blade assembly is rust resistant and stays sharp longer than conventional blades.

Safe - Every MAXX MIX features an automatic shut off feature in the event of an overload.

Efficient - The unique design of the stainless steel blade is designed with precise angles to ensure consistent mixing every time.

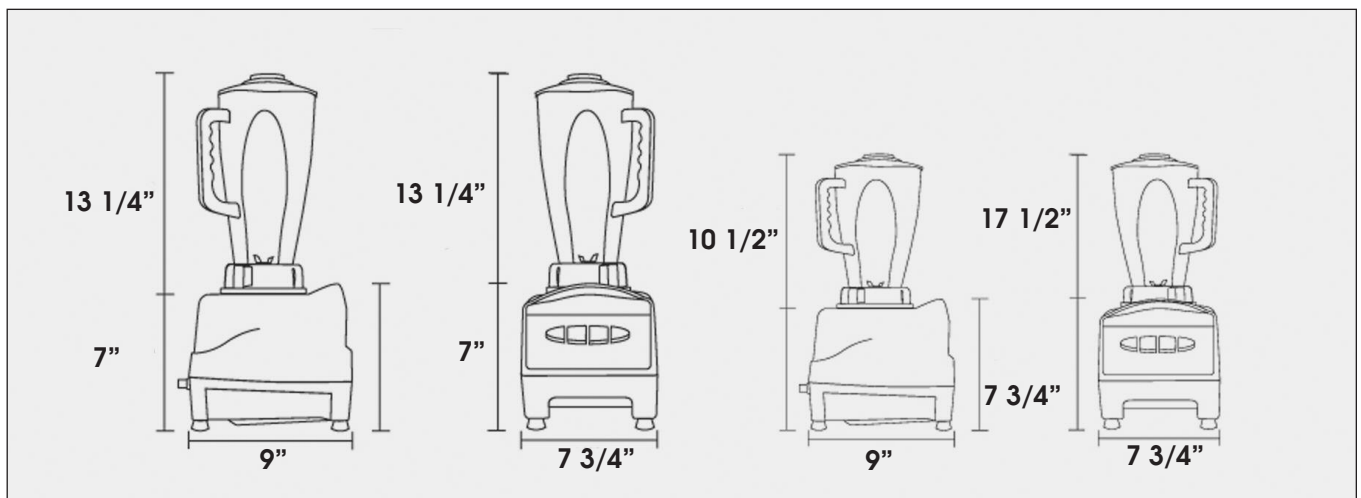

MAXXIMUM

HIGH PERFORMANCE PRODUCTS

COMMERCIAL HI-PERFORMANCE BLENDERS

15712 SW 41st Street • Suite 8 • Ft. Lauderdale, FL 33331

Tel: (954) 202-7419 • Fax: (954) 202-7337

www.asburyfoodservice.com